

Thermal-Link (OTCO)-Organic Type

RT Series I: 15A/16A



Description

Organic Thermal-Link (OTCO) RT series is defined as a non-resettable protective device, functioning one time only. It mainly consists of metal case, spring, sliding contact and thermal pellet. When the Thermal-Link senses abnormal heat and temp. reaches the predetermined fusing temp., thermal pellet melts and the sliding contact separates from the isolated lead with the assistance of the trip spring, thereby the circuit is disconnected

SETsafe | SETfuse Organic Thermal-Link (OTCO) RT series Rated Functioning Temp. from 72 °C to 310 °C, Rated Current: 16 A, Rated Voltage: 250VAC, safety certification Includes UL, cUL, PSE, VDE, KC, CCC, and complies with RoHS and REACH.

Features

- High Accuracy of Functioning Temp.
- Non-Resettable
- Organic Thermal Pellet
- Metal Case
- Low Resistance
- RoHS & REACH Compliant

Applications

- Kitchen and Toilet Appliance
- Personal Care Appliance
- Environment Appliances
- Cleaning Appliances
- Electric Tool
- Office Equipment
- Automotive Electronics

Customization

- Other Temp.
- The Length of Lead Wires
- Taping Packing Available
- Leads Forming Types

Cylindrical Structure Diagrams

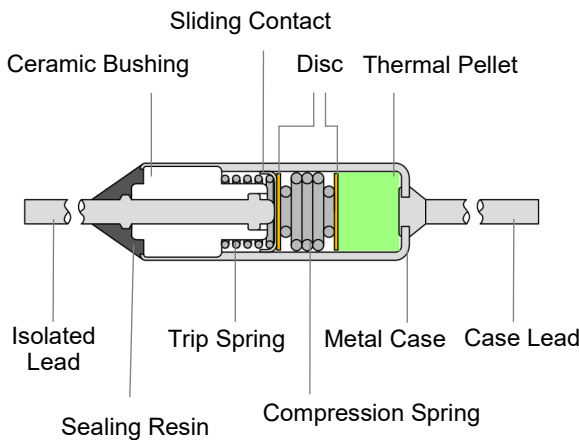

Square Structure Diagrams

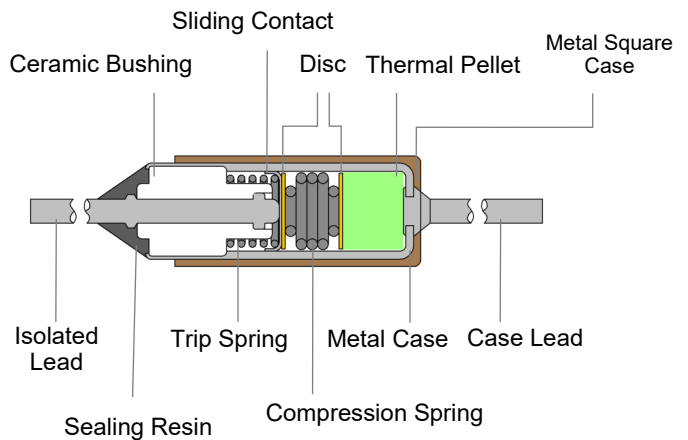

Cylindrical Structure Marking

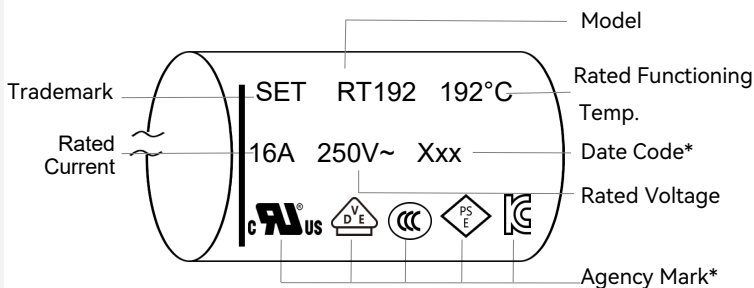

Square Structure Marking

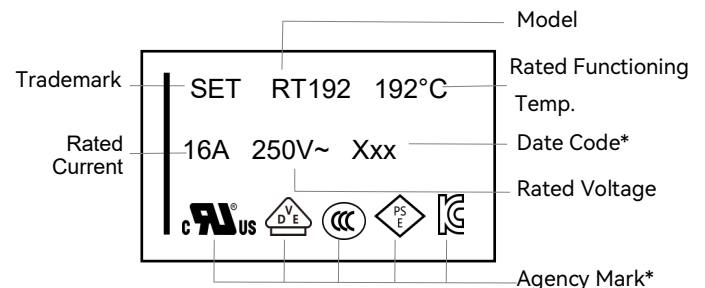

Remark:

1: The Date Code means Year and quarter: A stands for 2000, B stands for 2001 and 01 stands for the first quarter, 02 stands for the second quarter, and so on.

Cylindrical Structure Dimensions (mm)

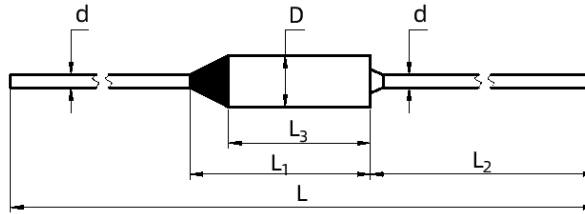

Lead Length	L	L ₁	L ₂	L ₃	D	d
Standard	65 ± 3	(14)	35 ± 2	(11.3)	Φ 4 ± 0.2	Φ 1 ± 0.1
Long	81 ± 3	(14)	35 ± 2	(11.3)	Φ 4 ± 0.2	Φ 1 ± 0.1
Option	Customization	(14)	Customization	(11.3)	Φ 4 ± 0.2	Φ 1 ± 0.1

Remark: The dimensions in parentheses are for reference only.

Square Structure Dimensions (mm)

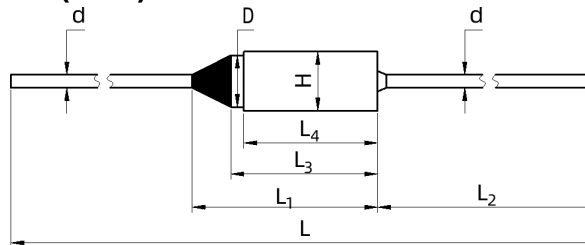

Lead Length	L	L ₁	L ₂	L ₃	L ₄	D	H	d
Standard	65 ± 3	(14)	35 ± 2	(11.3)	10.3 ± 0.5	Φ 4 ± 0.2	4.6 ± 0.3	Φ 1 ± 0.1
Long	81 ± 3	(14)	35 ± 2	(11.3)	10.3 ± 0.5	Φ 4 ± 0.2	4.6 ± 0.3	Φ 1 ± 0.1
Option	Customization	(14)	Customization	(11.3)	10.3 ± 0.5	Φ 4 ± 0.2	4.6 ± 0.3	Φ 1 ± 0.1

Remark: The dimensions in parentheses are for reference only.

Agency Information

Agency Symbol	Standards	The File No. and certification No. obtained by SETsafe SETfuse
	UL60691	E214712
	CAN-CSA-E60691	E214712
	EN60691	40052266
	J60691	JET2121-32001-2011、JET2121-32001-2012 JET2121-32001-2013、JET2121-32001-2014 JET2121-32001-2015、JET2121-32001-2016 JET2121-32001-2017、JET2121-32001-2018 JET2121-32001-2019、JET2121-32001-2020
	KC60691	SU05023-19001A、SU05023-19002A SU05023-19003B、SU05023-19004B SU05023-19005B
	GB/T 9816.1	2020980205000192

Specifications

Rated Functioning Temp. (T_f) °C

	Model	Fusing Temp.	T _h	T _h [*] (UL/ cUL)	T _h [*] (SET measured value)	T _m	I _r	U _r	I _n	I _{max}	UL [®]	cUL [®]	VDE	TUV	PSE	KC	CCC	RoHS REACH
		(°C)	(°C)	(°C)	(°C)	(°C)	(A)	(VAC)	(kA)	(kA)	UL	cUL	VDE	TUV	PSE	KC	CCC	
310	RT310	304 ± 3	215	280	280	500	16	250	1.5	3	●	●	○	○	○	○	○	●
275	RT275	273 +2/-3	215	260	260	500	16	250	1.5	3	●	●	○	○	○	○	○	●
263	RT263	261 ± 2	205	225	225	480	16	250	1.5	3	●	●	○	○	○	○	○	RoHS REACH *
257	RT257	254 ± 2	200	220	237	480	16	250	1.5	3	●	●	●	○	●	●	●	●
240	RT240	238 ± 2	200	205	220	450	16	250	1.5	3	●	●	●	○	●	●	●	●
229	RT229	227 ± 2	200	200	210	450	16	250	1.5	3	●	●	●	○	●	●	●	●
216	RT216	213 ± 2	186	200	203	450	16	250	1.5	3	●	●	●	○	●	●	●	●
205	RT205	203 ± 2	177	192	192	450	16	250	1.5	3	●	●	○	○	○	○	○	●
192	RT192	190 ± 2	162	177	179	300	16	250	1.5	3	●	●	●	○	●	●	●	●
184	RT184	181 ± 2	154	169	171	250	16	250	1.5	3	●	●	●	○	●	●	●	●
172	RT172	168 ± 2	143	157	159	260	16	250	1.5	3	●	●	●	○	●	●	●	●
167	RT167	164 ± 2	137	152	154	220	16	250	1.5	3	●	●	●	○	●	●	●	●
157	RT157	155 ± 2	129	144	144	450	16	250	1.5	3	●	●	○	○	○	○	○	●
152	RT152	149 ± 2	122	137	139	205	16	250	1.5	3	●	●	●	○	●	●	●	●
144	RT144	141 ± 2	114	129	131	300	16	250	1.5	3	●	●	●	○	●	●	●	●
134	RT134	131 ± 2	104	119	121	250	16	250	1.5	3	●	●	●	○	●	●	●	●
128	RT128	124 ± 2	98	113	115	200	16	250	1.5	3	●	●	●	○	●	●	●	●
121	RT121	118 ± 2	93	106	108	300	16	250	1.5	3	●	●	●	○	●	●	●	●
117	RT117	114 ± 2	88	102	104	200	16	250	1.5	3	●	●	●	○	●	●	●	●
110	RT110	108 ± 2	82	95	97	240	16	250	1.5	3	●	●	●	○	●	●	●	●
104	RT104	102 ± 2	74	89	91	250	16	250	1.5	3	●	●	●	○	●	●	●	●
99	RT99	95 ± 2	69	84	86	200	16	250	1.5	3	●	●	●	○	●	●	●	●
94	RT94	91 ± 2	64	79	81	300	16	250	1.5	3	●	●	●	○	●	●	●	●
84	RT84	82 ± 2	54	69	71	200	16	250	1.5	3	●	●	●	○	●	●	●	●
77	RT77	74 ± 2	50	62	64	300	16	250	1.5	3	●	●	●	○	●	○	●	●
72	RT72	69 ± 2	42	57	59	180	16	250	1.5	3	●	●	●	○	●	○	●	●

Note:

1. "●"Means certified, "○"Means non-certificated, "◐"Means Certification in progress, RoHS & REACH Compliant. " * " indicates that RT263 complies with REACH Directive 1907/2006/EC, SVHC Candidate List, Batch 29, Item 235 for most of the content (please consult SET for details).
2. For the T_h test, UL/CUL monitors the temperature of the product itself, while other standards monitor the ambient temperature inside the oven.
3. RT series with a T_f rating 175°C and above comply with UL conductive heat aging (CHAT) requirements.

Temp. Rise (Reference)

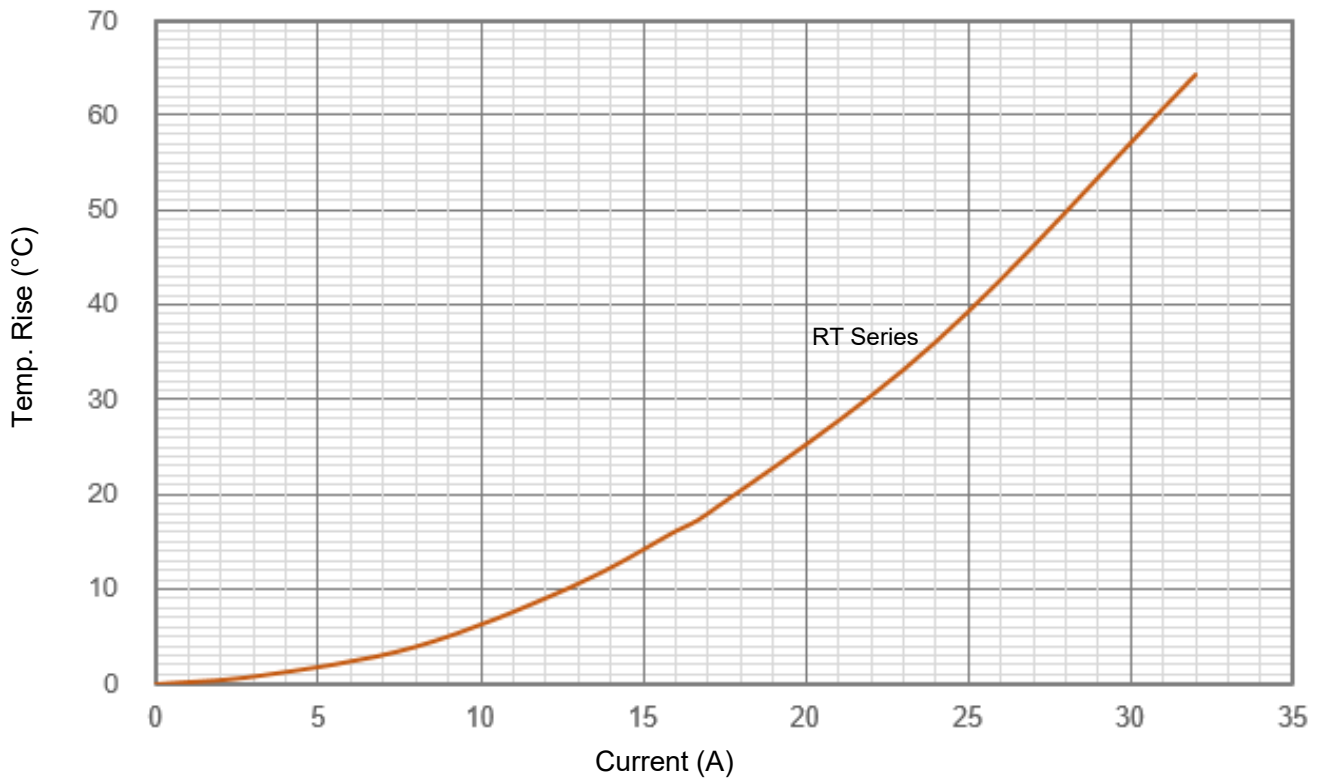

Response Time (Reference)

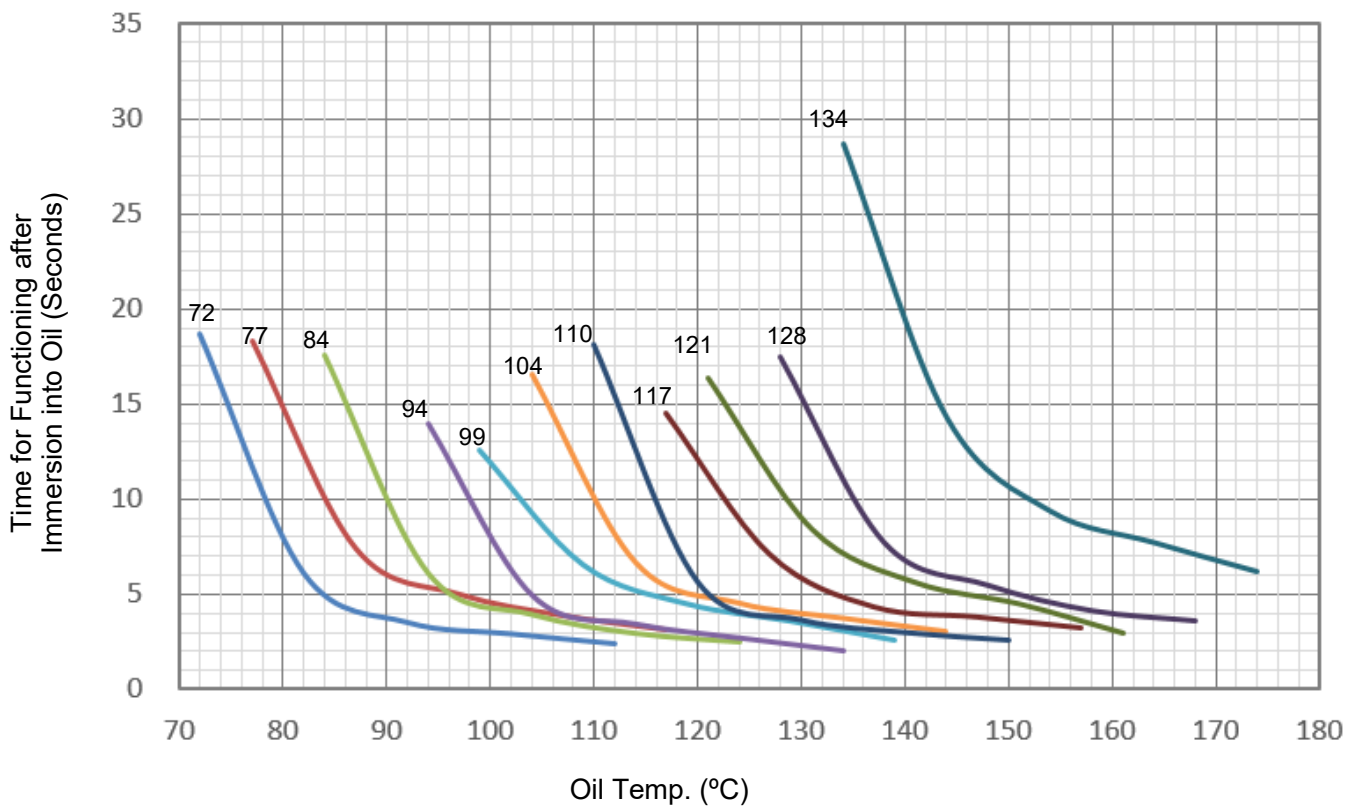

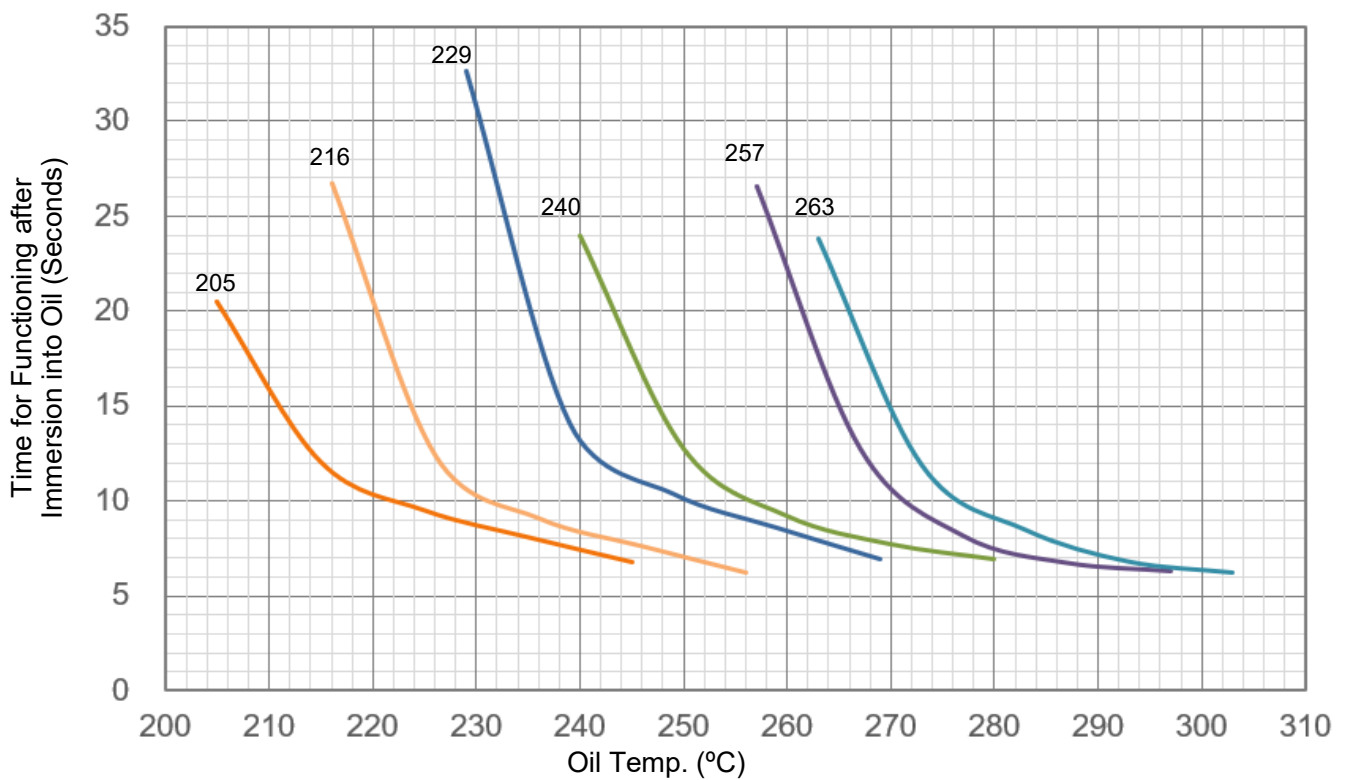
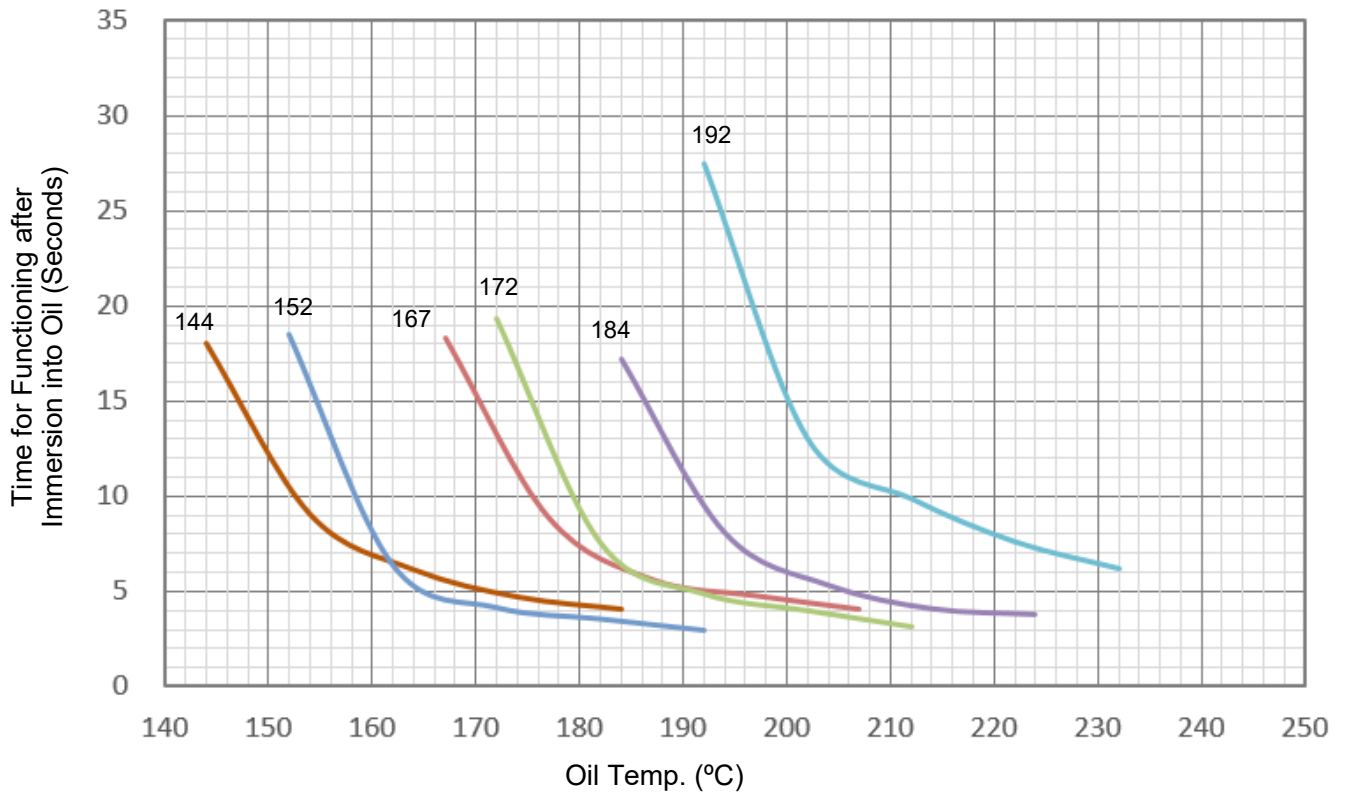

Note: The response time of 157/205/275/310 are testing, the temperature rise and response time testing of square products are continuously being updated. If you require any data, please consult SET.

Packaging Information

1. Bulk

Item	PE Bag	PE Bag	Carton
Dimensions (mm)	135 x 85	220 x 190	346 x 316 x 156
Quantity (PCS)	100	1000	10000
Gross Weight (kg)			Cylindrical: 11 ± 10% Square: 18 ± 10%

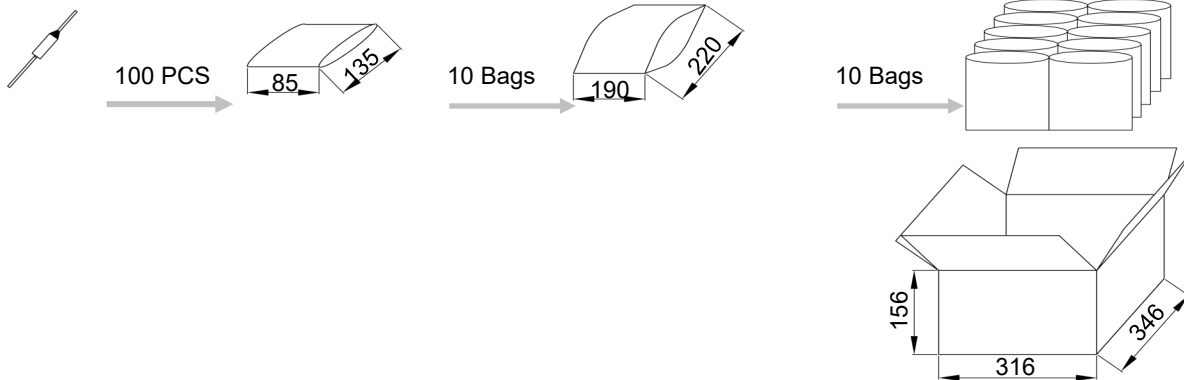

2. Taping

Item	Scroll	Box	Carton
Dimensions (mm)	Φ 250 x Φ 85 x 70	258 x 258 x 82	455 x 315 x 285
Quantity (PCS)	2000	2000	10000
Gross Weight (kg)			Cylindrical: 12.7 ± 10% Square: 19.7 ± 10%

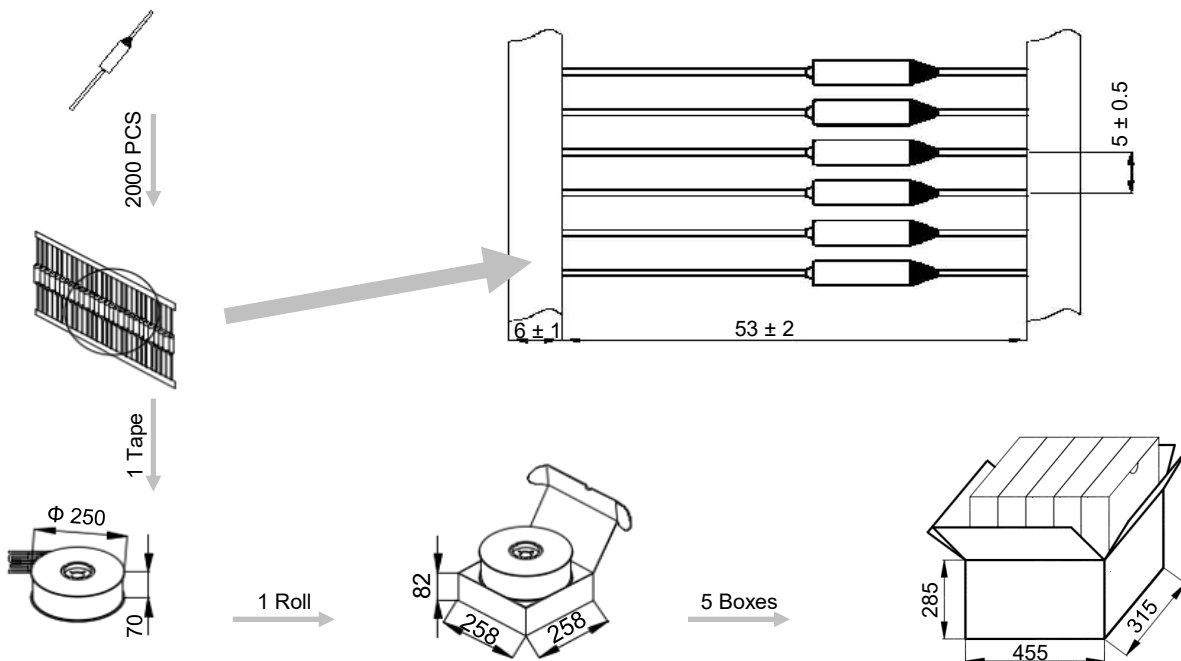

Part Numbering System

OTCO - RT 72 - L S A B - 001

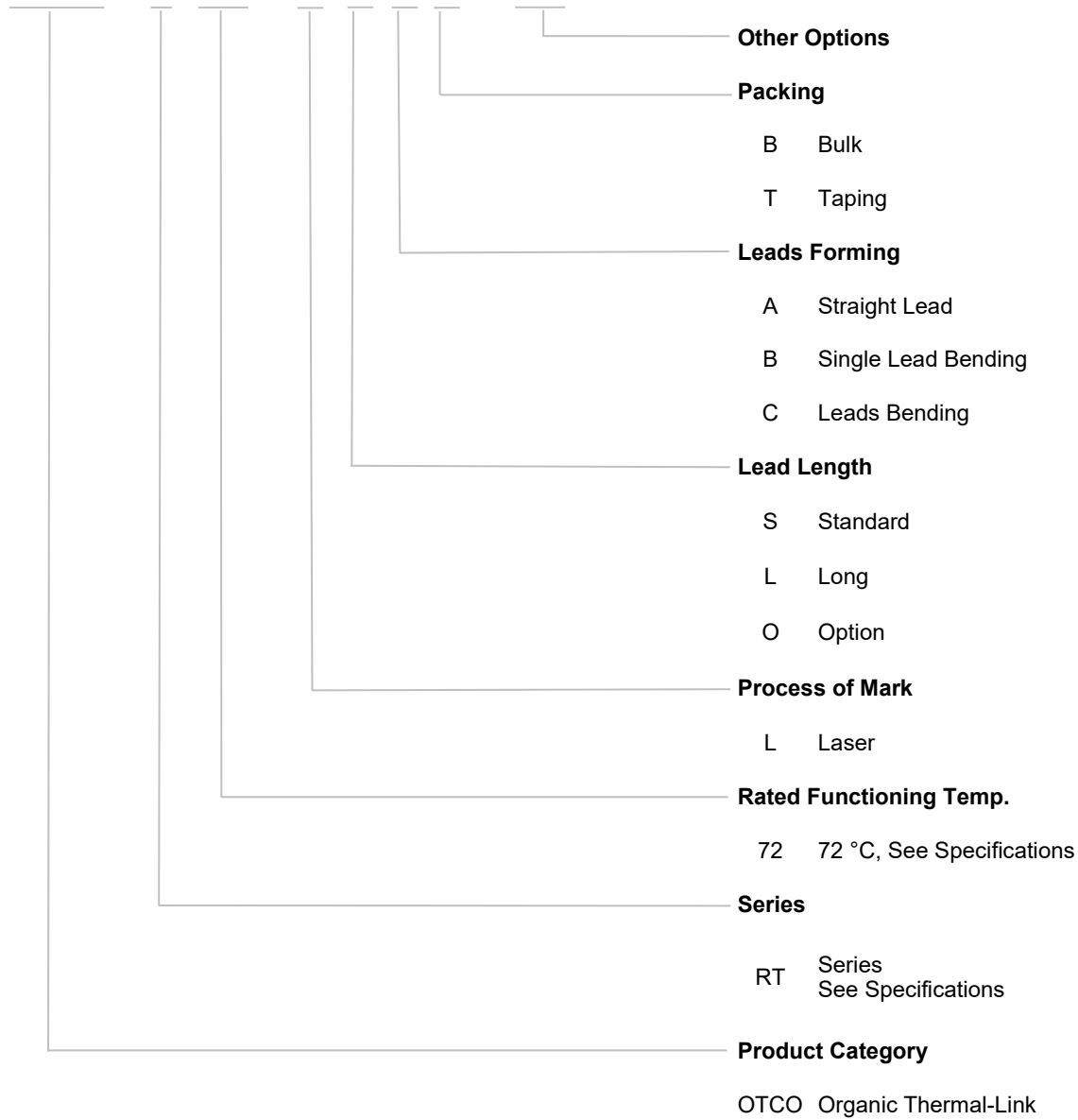

Glossary

Item	Description
TCO	<p>Thermal-Link</p> <p>A non-resettable device incorporating a THERMAL ELEMENT which will open a circuit once only when exposed for a sufficient length of time to a temperature in excess of that for which it has been designed.</p> <p style="text-align: right;">— (GB 9816.1)</p>
OTCO	<p>Organic Thermal-Link</p> <p>Organic type Thermal-Link, organic is the THERMAL ELEMENT.</p>
T_f	<p>Rated Functioning Temp.</p> <p>The temperature of the Alloy Thermal-Link which causes it to change the state of conductivity with a detection current up to 10 mA as the only load.</p> <p style="text-align: right;">— (GB 9816.1)</p> <p>Tolerance: T_f °C (GB 9816.1, EN 60691, K60691). Tolerance: $T_f \pm 7$ °C (J60691).</p>
Fusing Temp.	<p>Fusing Temp.</p> <p>The temperature of the Alloy Thermal-Link which causes it to change its state of conductivity is measured with silicone oil bath in which the temperature is increased at the rate of 0.5 °C to 1 °C / minute, with a detection current up to 10 mA as the only load.</p> <p style="text-align: right;">— (GB 9816.1)</p>
T_h	<p>Holding Temp.</p> <p>The Maximum temperature at which a Alloy Thermal-Link will not change its state of conductivity when conducting rated current for 168 hours.</p> <p style="text-align: right;">— (GB 9816.1)</p>
T_m	<p>Maximum Temp. Limit</p> <p>The temperature of the Alloy Thermal-Link stated by the manufacturer, up to which the mechanical and electrical properties of the Alloy Thermal-Link having changed its state of conductivity, will not be impaired for a given time.</p> <p style="text-align: right;">— (GB 9816.1)</p>
I_r	<p>Rated Current</p> <p>The current used to classify a Alloy Thermal-Link, which is the Maximum current that Alloy Thermal-Link allows to carry and is able to cut off the circuit safely.</p> <p style="text-align: right;">— (GB 9816.1)</p>
U_r	<p>Rated Voltage</p> <p>The voltage used to classify a Alloy Thermal-Link, which is the Maximum voltage that Alloy Thermal-Link allows to carry and is able to cut off the circuit safely.</p> <p style="text-align: right;">— (GB 9816.1)</p>
I_n	<p>Nominal Discharge Current</p> <p>Being able to withstand 15 peak currents of waveform 8/20 μs to test the product's durability of withstanding pulse current.</p> <p style="text-align: right;">— (UL 1449)</p>
I_{max}	<p>Max. Discharge Current</p> <p>Being able to withstand 1 peak current of waveform 8/20 μs to test max. pulse current that the product can withstand.</p> <p style="text-align: right;">— (UL 1449)</p>



ATTENTION

Usage

1. Please use OTCO without exceeding the rated current and voltage.
2. Do not use the OTCO in environments out of the standard specifications, such as those containing sulfur dioxide gas, nitrogen oxide gas, ammonia gas or formic acid. It is also not suitable for using in high humidity environment or immersed in liquid.

Replace

OTCO is a non-repairable product. For safety aspect, it shall be replaced by an equivalent OTCO from the same manufacturer, and mounted in the same way.

Storage

1. OTCO must be kept in a place with no sunshine or corrosive gas, the temperature shall be within 10 °C ~ 30 °C and humidity within 30 % ~ 70 %. The validity storage period of OTCO is 12 months after purchase.
2. The case and isolated lead of OTCO are silver-plated. Therefore, to avoid vulcanization, the OTCO shall not be kept around materials such as cardboard or rubber etc. which generate sulfurous acid gas.

Lead Process

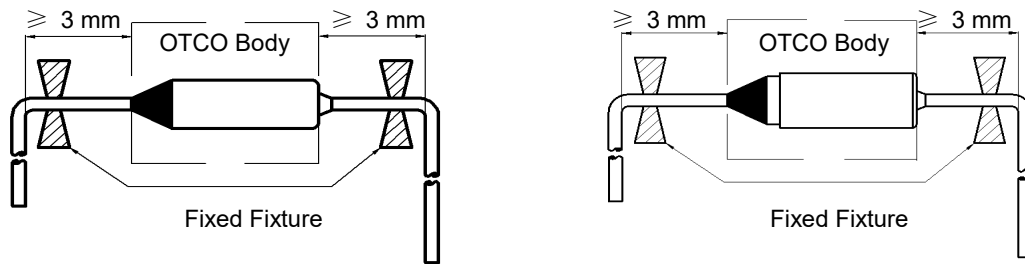

FIGURE 1

1. If lead wires has to be bent, it is important not to apply excessive pressure to the root of the lead wires. The tensile forces applied to the lead wires shall not exceed 15.7 N, and the thrust force applied to the lead wires shall not exceed 3.9 N.
2. The lead wires should be bent at a distance 3 mm or above from the body of OTCO (see Fig.1).
3. To avoid damaging the OTCO, when bending lead wires, please use pincher or similar tools to fix the OTCO.

Installation

Selection of Installation Location

1. Do not locate the OTCO in a place where severe vibration always occurs.
2. To reduce the deviations between the temperature design and the actual situation, it is recommended that the OTCO be installed in close to the thermostat or temperature sensor.

Make Sure the Temp. of Installation Location

1. The body of OTCO will generate heat as current flows through it, resulting the body temp. higher than ambient temp. The influence of temp. rise shall be considered in the design to determine the appropriate OTCO model.
2. It Considering possible temperature shock situations, it is recommended that the temperature of the body and the ambient temperature of the installation location during the operation of the temperature fuse should not exceed $(T_h-10)^\circ\text{C}$.
3. The end product should be tested to ensure that potential abnormal conditions do not cause ambient temp. to exceed the T_m of the OTCO.

Mounting OTCO

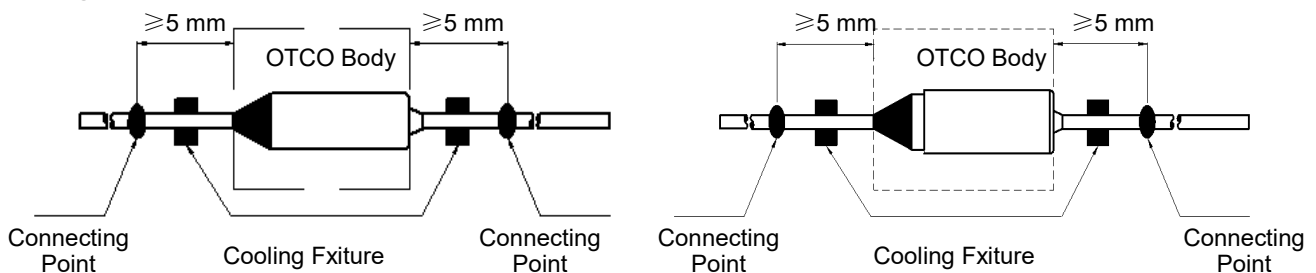

FIGURE 2

1. OTCO can be installed by soldering, welding, riveting or crimping. During and after installation, please do not pull, push or twist OTCO body or lead wires.
2. The connection point of the lead shall be no less than 5 mm away from the OTCO body (see Fig.2).
3. Try to ensure that the body of the OTCO is evenly heated. If the temp. difference is inevitable, make sure that the sealing resin side is connected close to the heat source.

Soldering

1. Soldering should be carried out according to below table. If secondary soldering is required, wait until the OTCO cools to room temp.
2. Soldering is not recommended for Thermal-Link with $T_f \leq 110^\circ\text{C}$, while non heating processes such as crimping and riveting are recommended.
3. In the process of soldering, cooling fixture should be used between soldering point and OTCO body (see Fig.2).
4. It is recommended to take X-ray after soldering, to confirm that the thermal pellet has no shrinkage after soldering.

TABLE 1: Max. Allowable Soldering Time for Different Length of Soldering Point from OTCO Body

Rated Functioning Temp. (T_f)	Length	Time	Length	Time	Length	Time	Max. Soldering Temp.
($^\circ\text{C}$)	(mm)	(s)	(mm)	(s)	(mm)	(s)	($^\circ\text{C}$)
≤ 110	5	N / A	15	N / A	25	N / A	400
111 ~ 150	5	N / A	15	1	25	2	
151 ~ 190	5	1	15	2	25	3	
≥ 191	5	1	15	3	25	5	

Welding

1. Avoid welding current flowing into the inside of the OTCO. The welding current will cause the internal parts to be welded together, resulting in the failure function of OTCO.
2. During the welding process, the lead wires of the OTCO must be supported to avoid the damage of the OTCO.
3. In the process of welding, cooling fixture should be used between welding point and OTCO body (See Fig.2).
4. It is recommended to take X-ray after welding, to confirm that the thermal pellet has no shrinkage after welding.

Riveting or Crimping

1. Select materials with low resistance (such as copper) for riveting and crimping.
2. Contact resistance shall be as small as possible. Large contact resistance will cause high temp. to make OTCO open in advance.
3. It is better to crimp OTCO leads to stranded lead wires rather than solid wires as the stranded wire may be crimped tighter and maintain better electrical contact during temp. cycling.
4. During the riveting and crimping process, ensure that the lead wires shall not be reversed, sealing resin shall not be destroyed.
5. When the working temp. exceeds 150°C , soldering reinforcement is recommended after riveting and crimping.

The isolated lead is forbidden to contact OTCO body directly to avoid short circuit (See Fig.3).

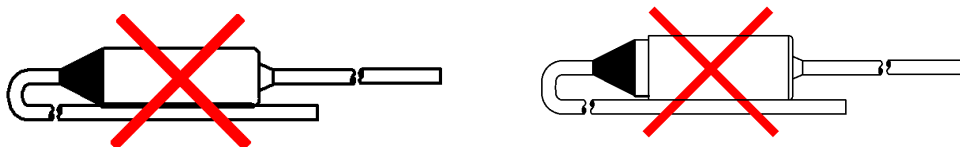

FIGURE 3

Thermal-Link (OTCO)-Organic Type

RT Series I: 15A/16A

Thermal-Link (OTCO) - Organic Type Features & Model List Overview

Rated Functioning Temp. T_f (°C)	Rated Current I_r (A)	Rated Voltage U_r (VDC)	Model			
310	10	250 VAC	RB310			
			RS310			
			RT310			
			RK310			
			RU310			
			RP310			
			RL310			
			RM310			
			275	10 / 15	24 VDC	RB275
						RS275
RT275						
RK275						
RU275						
RP275						
RL275						
RM275						
263	16	24 VDC				RB263
						RS263
			RT263			
			RK263			
			RU263			
			RP263			
			RL263			
			RM263			
			257	16	24 VDC	RB257
						RS257
RT257						
RK257						
RU257						
RP257						
RL257						
RM257						
240	16	24 VDC				RB240
						RS240
			RT240			
			RK240			
			RU240			
			RP240			
			RL240			
			RM240			
			229	16	24 VDC	RB229
						RS229
RT229						
RK229						
RU229						
RP229						
RL229						
RM229						
216	16	24 VDC				RB216
						RS216
			RT216			
			RK216			
			RU216			
			RP216			
			RL216			
			RM216			
			205	16	24 VDC	RB205
						RS205
RT205						
RK205						
RU205						
RP205						
RL205						
RM205						
192	16	24 VDC				RB192
						RS192
			RT192			
			RK192			
			RU192			
			RP192			
			RL192			
			RM192			
			184	16	24 VDC	RB184
						RS184
RT184						
RK184						
RU184						
RP184						
RL184						
RM184						
172	16	24 VDC				RB172
						RS172
			RT172			
			RK172			
			RU172			
			RP172			
			RL172			
			RM172			
			167	16	24 VDC	RB167
						RS167
RT167						
RK167						
RU167						
RP167						
RL167						
RM167						
157	16	24 VDC				RB157
						RS157
			RT157			
			RK157			
			RU157			
			RP157			
			RL157			
			RM157			
			152	16	24 VDC	RB152
						RS152
RT152						
RK152						
RU152						
RP152						
RL152						
RM152						
144	16	24 VDC				RB144
						RS144
			RT144			
			RK144			
			RU144			
			RP144			
			RL144			
			RM144			
			134	16	24 VDC	RB134
						RS134
RT134						
RK134						
RU134						
RP134						
RL134						
RM134						
128	16	24 VDC				RB128
						RS128
			RT128			
			RK128			
			RU128			
			RP128			
			RL128			
			RM128			
			121	16	24 VDC	RB121
						RS121
RT121						
RK121						
RU121						
RP121						
RL121						
RM121						
117	16	24 VDC				RB117
						RS117
			RT117			
			RK117			
			RU117			
			RP117			
			RL117			
			RM117			
			110	16	24 VDC	RB110
						RS110
RT110						
RK110						
RU110						
RP110						
RL110						
RM110						
104	16	24 VDC				RB104
						RS104
			RT104			
			RK104			
			RU104			
			RP104			
			RL104			
			RM104			
			99	16	24 VDC	RB99
						RS99
RT99						
RK99						
RU99						
RP99						
RL99						
RM99						
98	16	24 VDC				RB98
						RS98
			RT98			
			RK98			
			RU98			
			RP98			
			RL98			
			RM98			
			94	16	24 VDC	RB94
						RS94
RT94						
RK94						
RU94						
RP94						
RL94						
RM94						
84	16	24 VDC				RB84
						RS84
			RT84			
			RK84			
			RU84			
			RP84			
			RL84			
			RM84			
			77	16	24 VDC	RB77
						RS77
RT77						
RK77						
RU77						
RP77						
RL77						
RM77						
72	16	24 VDC				RB72
						RS72
			RT72			
			RK72			
			RU72			
			RP72			
			RL72			
			RM72			

